

REV	E.C.N NO.	CONTENT	CHK	DATE
V0.1		Update method of screw discription	ZY	2021.11.26

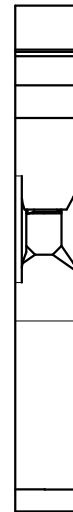
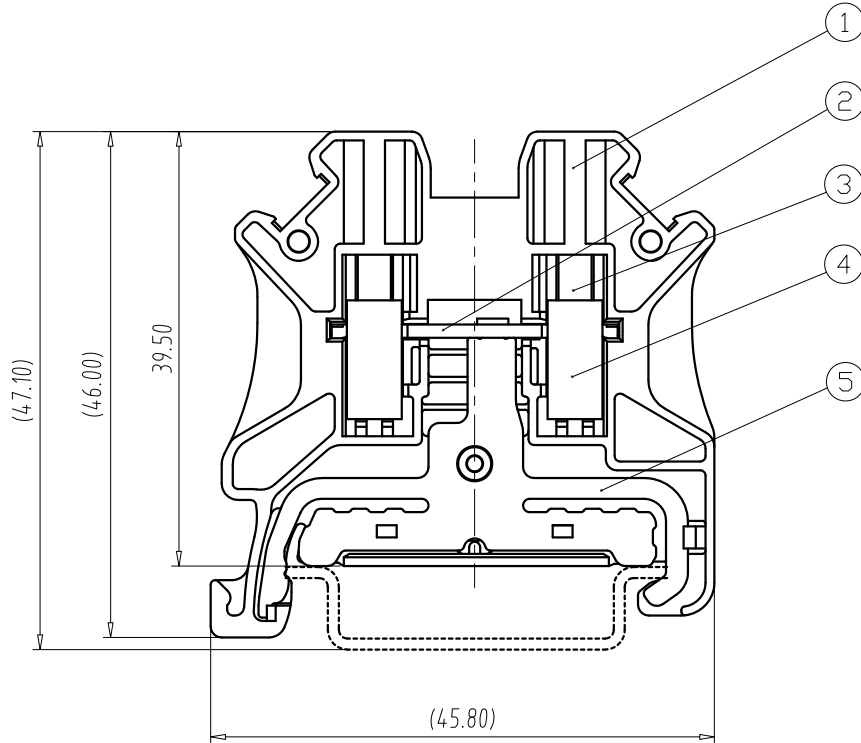
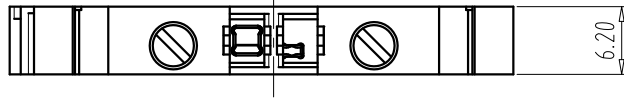

NOTES:

1. IEC:

- Rate Impulse Voltage:8000V;
- Insulation Resistance:500MΩ or more at DC500V;
- Contact Resistance: ≤5mΩ
- Material Group: I ;
- Pollution Degree:3;
- Overvoltage Category:III;
- Suitable Electric Wire:0.2mm²~4mm²&6mm² (SOL)

2. UL:

- Rating: 600V;
- Suitable Electric Wire:26AWG~10AWG
- 3.Using Temperature Range:-40℃~+115℃;
- 4.Screw Torque Value:0.5N·m

5.Strip length:9mm

6.RoHS compliance;

TK4-PE(S)

→ Slot screw

5	GROUNDING	1	H-Copper Alloy	Tin Plated
4	BLOCK	2	Copper Alloy	M3/Ni Plated
3	SCREW	2	STEEL	M3/Zn Plated
2	CURRENT CARRIER	1	Copper Alloy	Tin Plated
1	HOUSING	1	PA66	Yellow+Green UL94V-0
ITEM	NAME OF PART	Q'TY	MATERIAL	NOTE

Total Pitch Tolerances in mm										Nominal dimension range in mm									
over 0	over 30	over 53	over 70	over 90	over 115	over 150	over 200	over 250	over 300	over 0	over 30	over 53	over 70	over 90	over 115	over 150	over 200	over 250	over 320
±0.20	±0.25	±0.3	±0.35	±0.44	±0.55	±0.70	±0.85	±1.00	±1.20	±0.25	±0.30	±0.35	±0.44	±0.55	±0.70	±0.80	±0.90	±1.20	

DWG.	ZY	DATE	2021.01.13	UNITS	MM	SHEET/OF	1/1
CHK.		DATE		SCALE	15 : 1	A4	
APP.		DATE		NAME: TK4-PE(S) DWGNO: TLDW-TK4PES			
TIANLI ELECTRICAL MACHINERY(NINGBO)CO.,LTD.							