

FILE: TK\TK35-PE(S)

REV	E.C.N NO.	CONTENT	CHK	DATE
V0.1		Update the drawing	ZY	2024.07.27

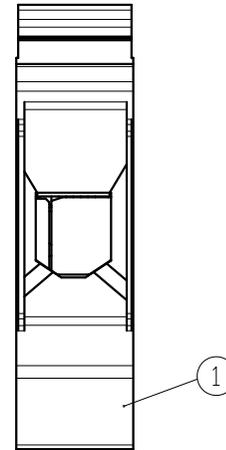
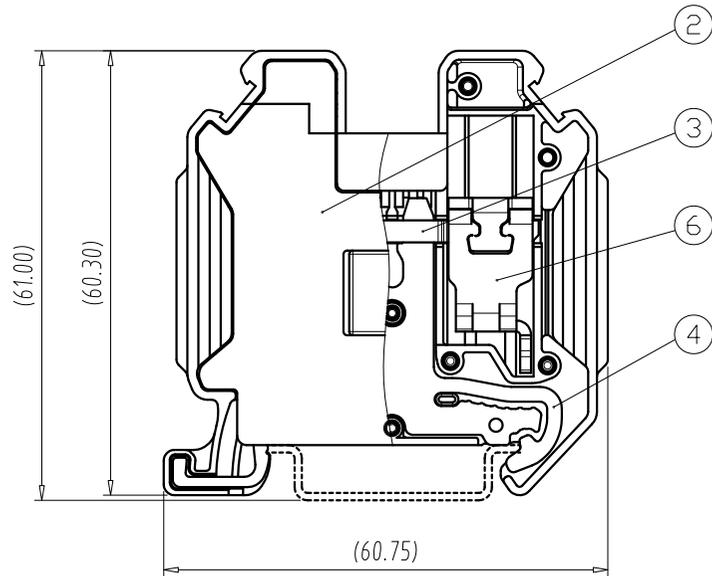
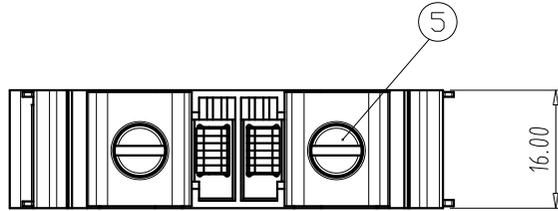

NOTES:

1. IEC:
 - Rate Impulse Voltage:8000V;
 - Insulation Resistance:500MΩ or more at DC500V;
 - Contact Resistance: ≤5mΩ;
 - Material Group: I;
 - Pollution Degree:3;
 - Overvoltage Category:III;
 - Suitable Electric Wire:1.5mm²~35mm²&50mm² (rigid);
2. UL:
 - Rating:1000V;
 - Insulation Withstands Voltage:AC4250V/MIN;
 - Suitable Electric Wire:14AWG~1/0AWG;
3. Using Temperature Range:-40℃~+115℃;
4. Screw Torque Value:3.5N·m;
5. Strip length:14.0~16.0mm;
6. RoHS compliance.

TK35-PE(S)

Slot screw

ITEM	NAME OF PART	Q'TY	MATERIAL	NOTE
6	CAGE	2	STEEL	M6/Zn Plated
5	SCREW	2	STEEL	M6/Zn Plated
4	GROUNDING	6	Copper Alloy	Tin Plated
3	CURRENT CARRIER	1	Copper Alloy	Tin Plated
2	COVER	1	PA66	UL94V-0
1	HOUSING	1	PA66	UL94V-0

Total Pitch Tolerances in mm										Nominal dimension range in mm									
over 0	over 30	over 53	over 70	over 90	over 115	over 150	over 200	over 250	over 300	over 0	over 30	over 53	over 70	over 90	over 115	over 150	over 200	over 250	over 300
to 30	to 53	to 70	to 90	to 115	to 150	to 200	to 250	to 300	to 320	to 30	to 53	to 70	to 90	to 115	to 150	to 200	to 250	to 300	to 320
±0.20	±0.25	±0.3	±0.35	±0.44	±0.55	±0.70	±0.85	±1.00	±1.20	±0.25	±0.30	±0.35	±0.44	±0.55	±0.70	±0.80	±0.90	±1.20	

DWG.	ZY	DATE	2023.04.10	UNITS	MM	SHEET/OF	1/1				
CHK.		DATE		SCALE	1:1	A4					
APP.		DATE		<table border="1"> <tr> <td>NAME</td> <td>TK35-PE(S)</td> </tr> <tr> <td>DWGNO.</td> <td>TLDW-TK35PE(S)</td> </tr> </table>				NAME	TK35-PE(S)	DWGNO.	TLDW-TK35PE(S)
NAME	TK35-PE(S)										
DWGNO.	TLDW-TK35PE(S)										
 TIANLI ELECTRICAL MACHINERY(NINGBO)CO.,LTD.											